

LeeSti Pendant

Installation Instructions

archlit
architecture lit

1. Disconnect electrical power from lighting circuit before installation.
2. CAUTION-RISK OF FIRE. This product must be installed in accordance with the applicable NEC/local installation code by a person familiar with the construction and operation of the product and the hazards involved.
3. Make sure LED drivers, Linear LED Modules and all other fixture components are present.
4. This installation assumes Class 2 two conductor wires have been run from fixture mount location to LED driver enclosure location.
5. LED driver enclosure must be installed in an accessible, dry and well ventilated location, using the screw holes provided in enclosure.
6. Make wire connection from LED driver to two conductor Class 2 wire, running in ceiling with wire nuts (not included). Then make wire connection from LED module canopy to exposed Class 2 wire with wire nuts at j-Box.

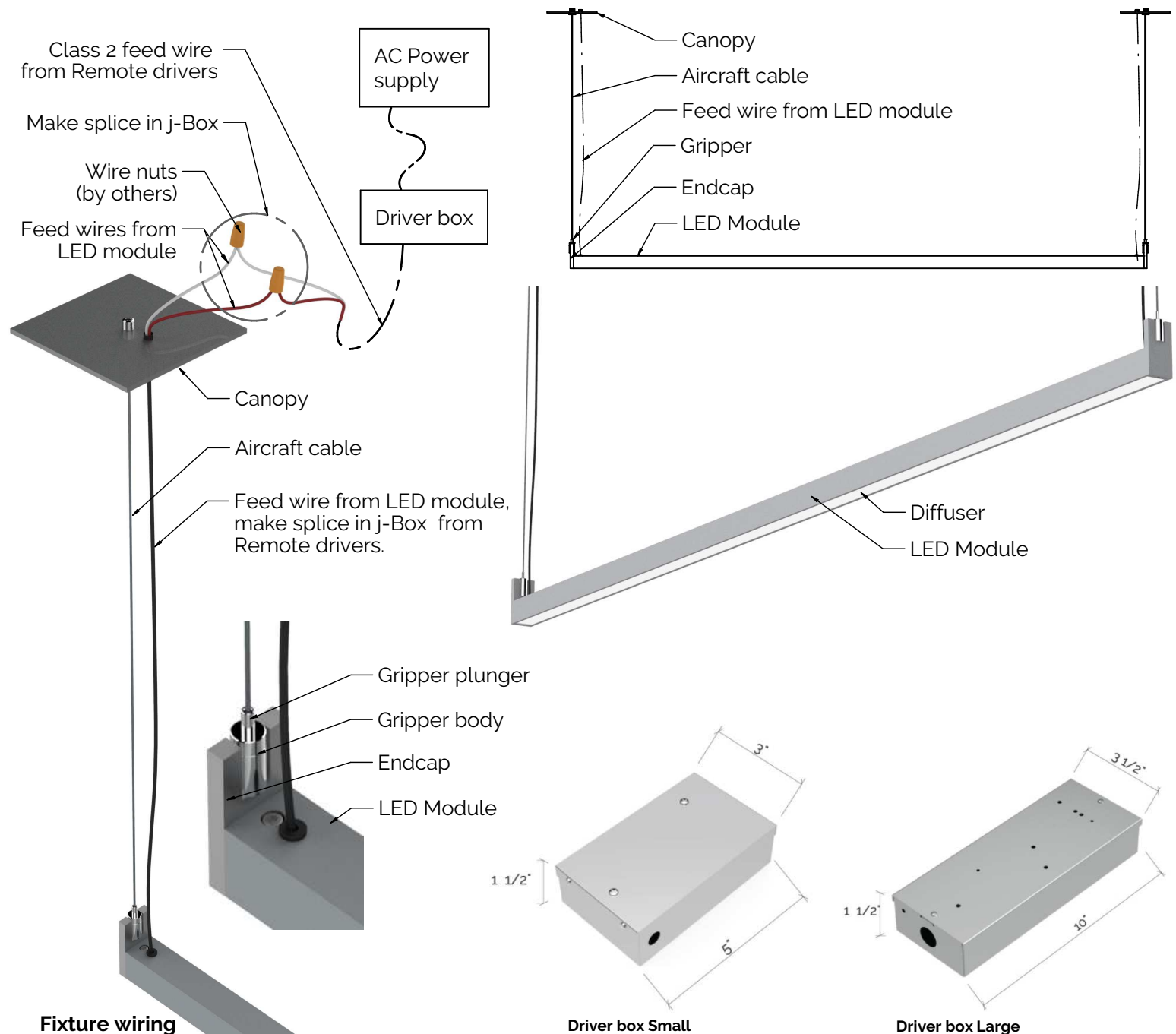

LeeSti Pendant

Installation Instructions

7. If more than one fixture is to be connected in a continuous line, then make the joint between two LED modules using Mid-support endcap and follow step 6 for each module.
8. After j-Box wiring is complete, install j-Box Strap to j-Box. Secure LED pendant and Canopy to j-Box by hand tightening Suspension Cable Knob into j-Box Strap or directly to ceiling using C-slot gripper for non powered end, whichever is applicable. Adjust fixture height and cable length by pushing gripper plunger down to release cable.
9. Make sure fixture is well secured to ceiling and there are no pinched or exposed wires.
10. Make Mains power connection to LED driver using provided connector inside driver enclosure. Make sure Mains power Ground wire is secured to green ground wire inside driver enclosure.
11. Restore Mains power.

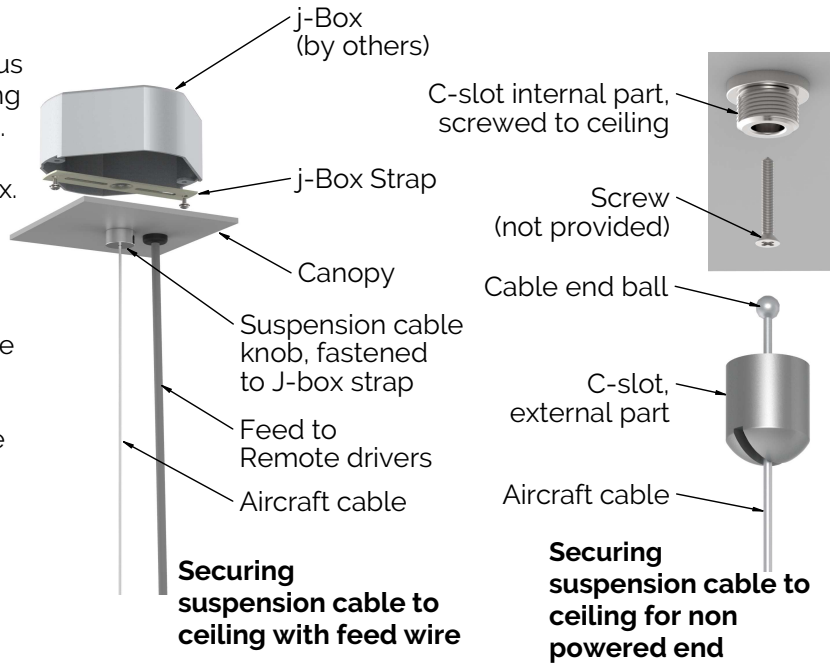

Two modules in continuous line

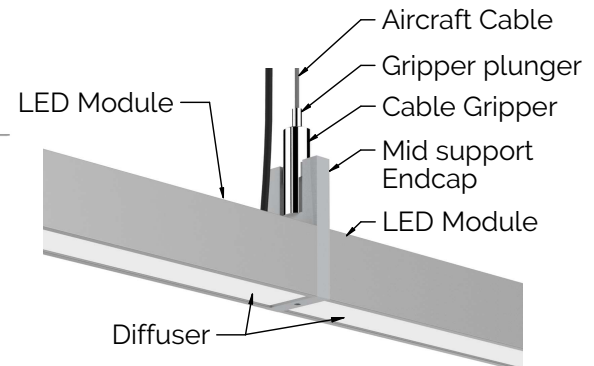

Connecting two or more modules

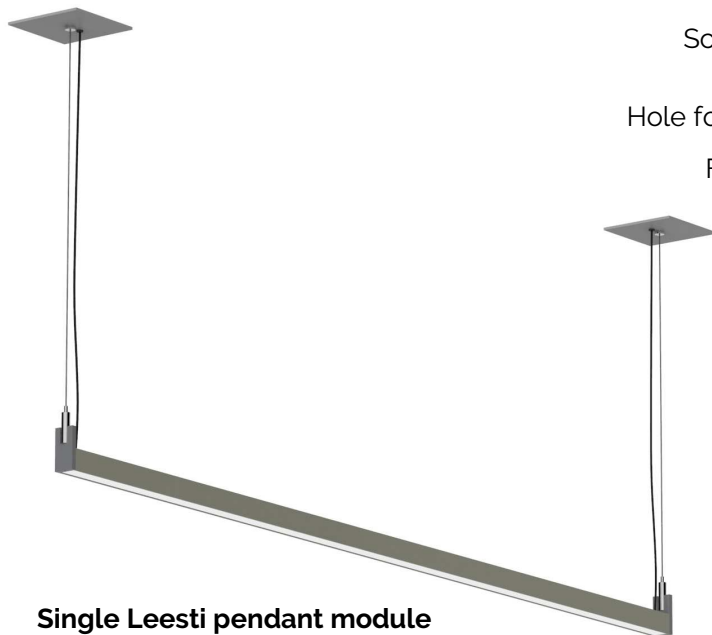

Single LeeSti pendant module
(Power feed at both ends)

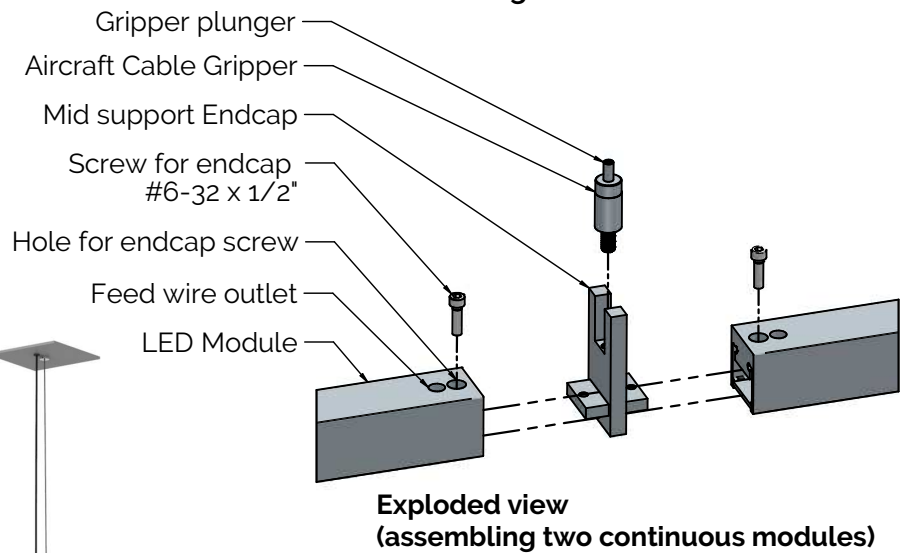

Exploded view
(assembling two continuous modules)



Perspective View from below