

LeeSti Downlight

Installation Instructions

1. Disconnect electrical power from lighting circuit before installation.
2. CAUTION-RISK OF FIRE. This product must be installed in accordance with the applicable NEC/local installation code by a person familiar with the construction and operation of the product and the hazards involved.
3. Make sure LED drivers, Linear LED Modules and all other fixture components are present.
4. This installation assumes Class 2 two conductor wires have been run from fixture mount location to LED driver enclosure location.
5. LED driver enclosure must be installed in an accessible, dry and well ventilated location, using the screw holes provided in enclosure.
6. Make wire connection from LED driver to two conductor Class 2 wire, running in ceiling with wire nuts (not included).

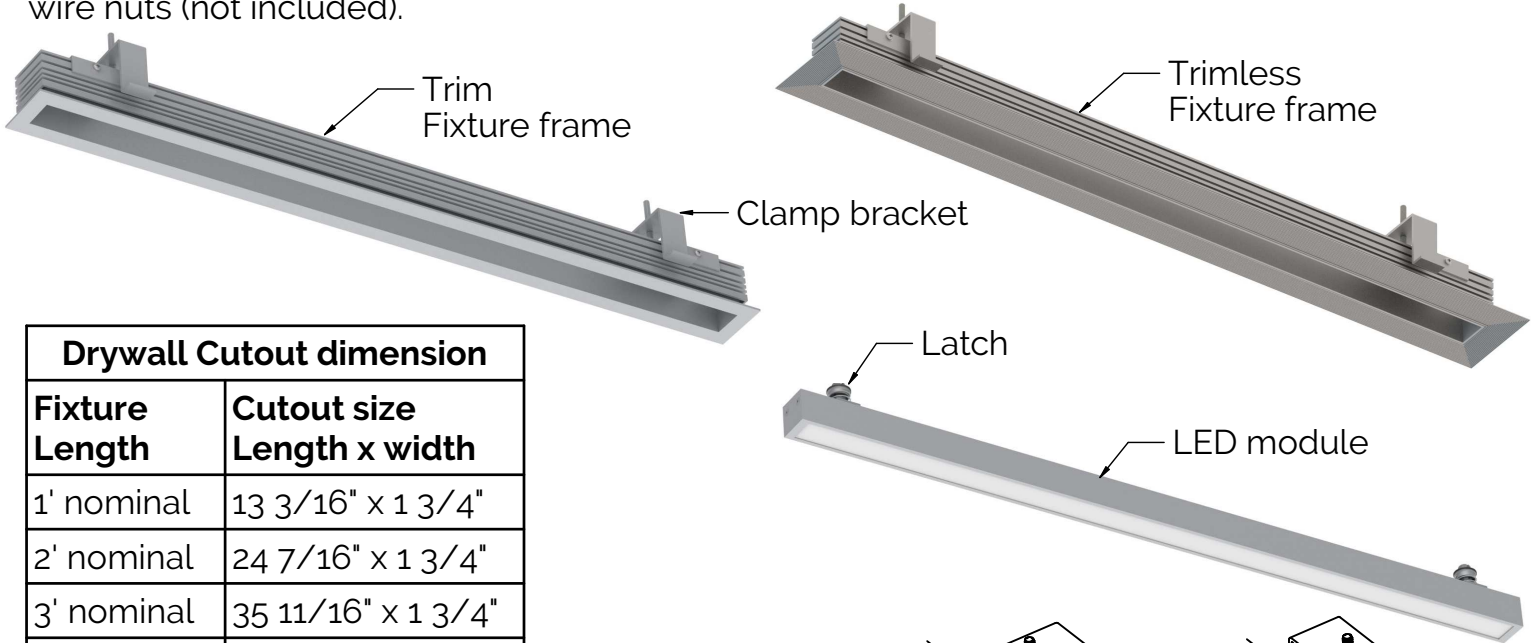

Drywall Cutout dimension	
Fixture Length	Cutout size Length x width
1' nominal	13 3/16" x 1 3/4"
2' nominal	24 7/16" x 1 3/4"
3' nominal	35 11/16" x 1 3/4"
4' nominal	46 11/16" x 1 3/4"

7. Cut-out the opening in wall/ceiling for inserting Frame.

8. To insert frame into Cut-out, make the clamp bracket to lift up and rotate it 90°, so that it causes no hinderance while inserting frame.

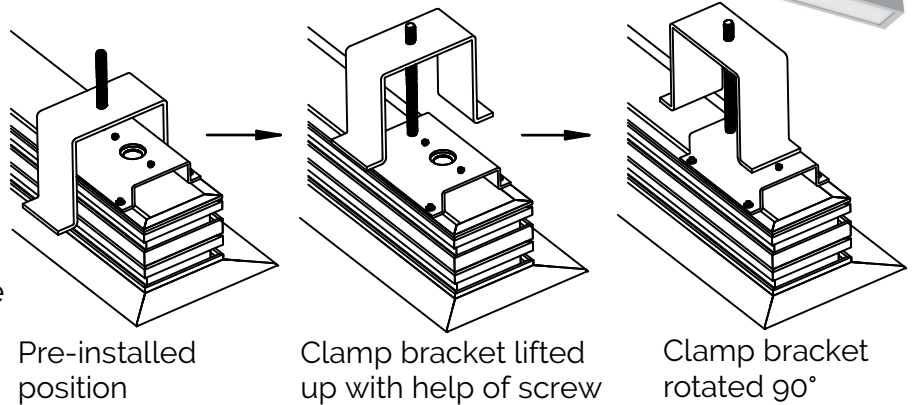

9. Insert fixture frame into ceiling opening so that only flange is seen at surface.

10. Rotate clamp bracket 90° again, so it slides down over frame. Tighten clamp bracket screw until Clamp bracket has secured frame in ceiling opening. Do not over-tighten clamp bracket as it may damage the fixture.

LeeSti Downlight

Installation Instructions

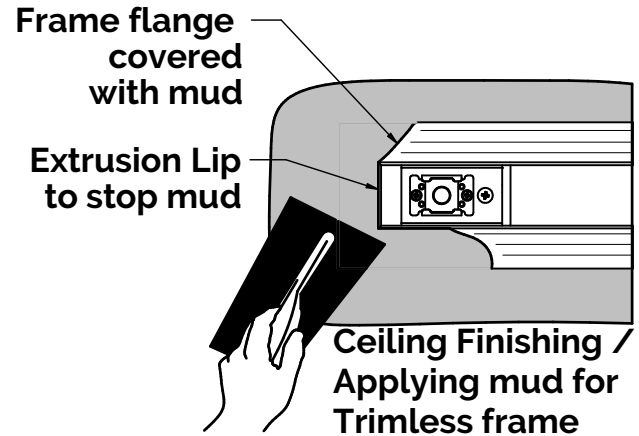
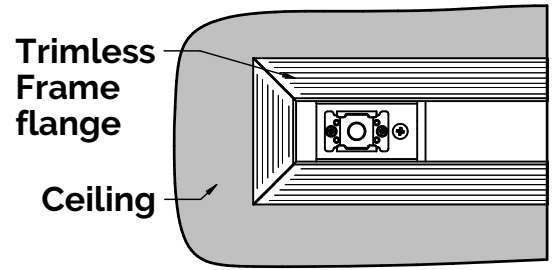
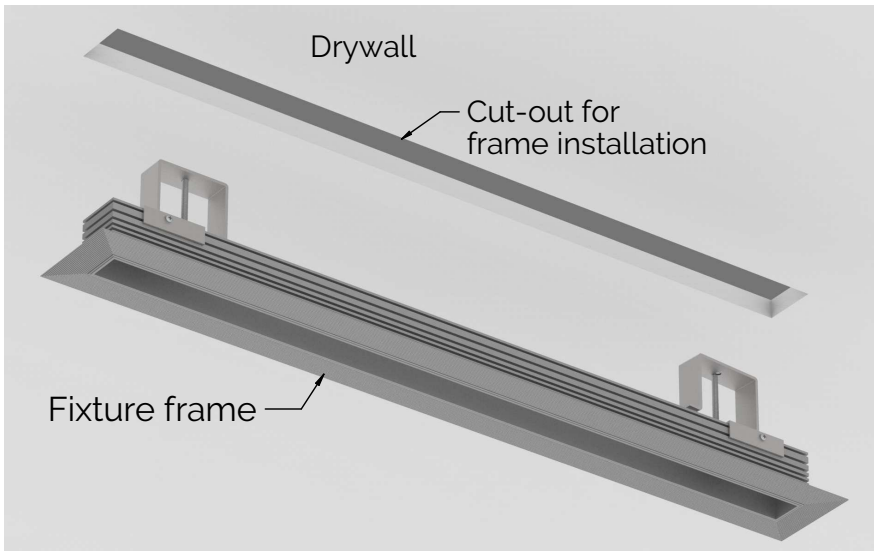

11. For trimless frame, finish ceiling by apply mud around trimless edges of frame. Extrusion has lip for stopping mud (donot go over internal part of frame).

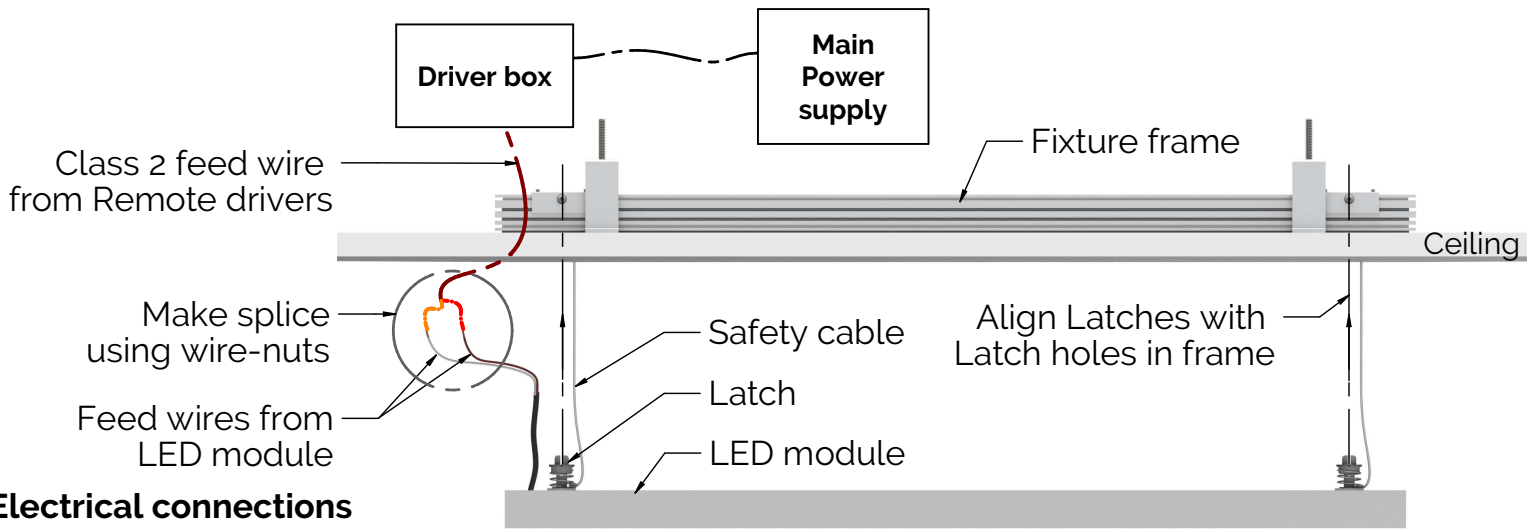

Electrical connections and installing LED module

12. Connect LED module to Remote drivers (whip). Make sure LED module is attached to Fixture frame by a safety cable (aircraft cable) to avoid damage or injury.

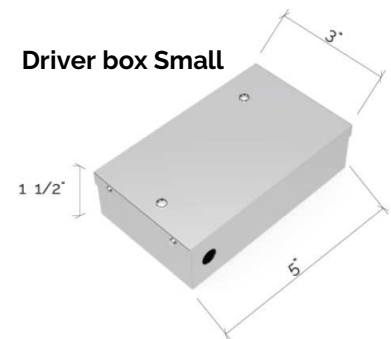
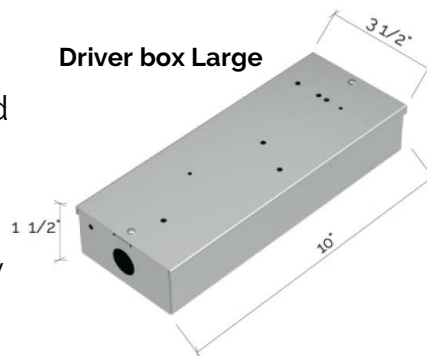

13. Insert LED module into frame completely by aligning Latches to latch hole and gently pushing upwards untill a 'Click' is heard from spring Latches. LED module must be secured in fixture frame at this point.

14. Connect AC Power Lead from LED Drivers to disconnected Mains power. Restore Mains power.

LeeSti Downlight

Installation Instructions

