

LeeSti Legato Ceiling Trimless

Installation Instructions

PLEASE READ THESE INSTRUCTIONS PRIOR TO INSTALLING THIS PRODUCT

CAUTION – RISK OF FIRE. THIS PRODUCT MUST BE INSTALLED IN ACCORDANCE WITH THE APPLICABLE NEC/LOCAL INSTALLATION CODE BY A PERSON FAMILIAR WITH THE CONSTRUCTION AND OPERATION OF THE PRODUCT AND HAZARDS INVOLVED.

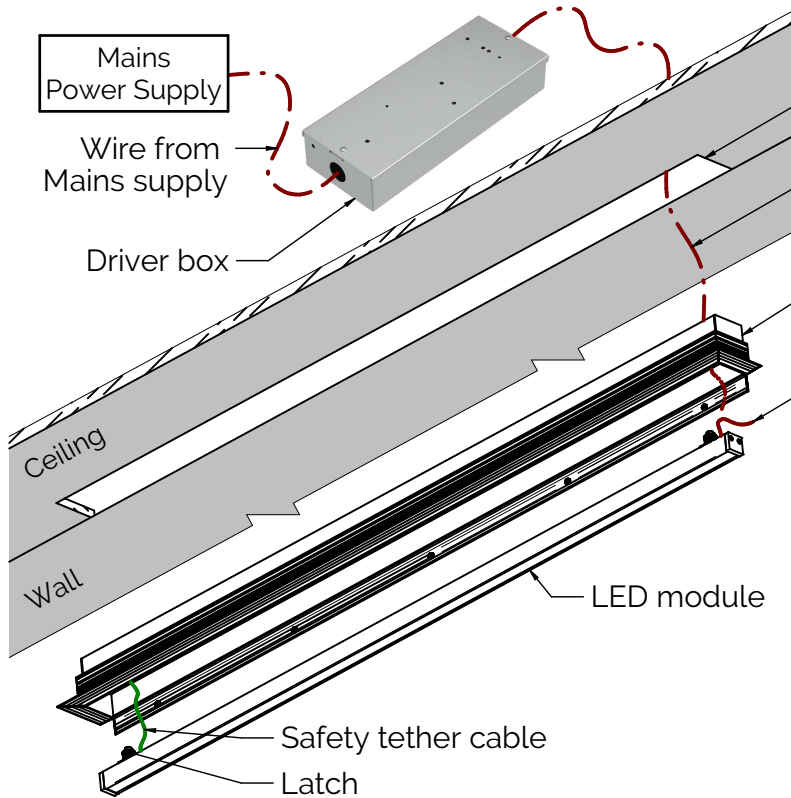

1. Disconnect electrical power from lighting circuit at breaker panel before installation.
2. Make sure LED drivers, Linear LED Modules and fixture frame components are present.
3. Cut-out the opening in wall/ceiling for inserting fixture frame as per fixture length (refer to job submittal).
4. Insert fixture frame into ceiling opening so that only flange is seen at surface.
5. Secure the frame in place using drywall screws(not provided) at marked places on trimless frame. Make sure screws anchor into the blocking behind the ceiling/wall.
6. Use Mud around trimless edges of frame. Extrusion has lip for stopping mud (donot go over internal part of frame).

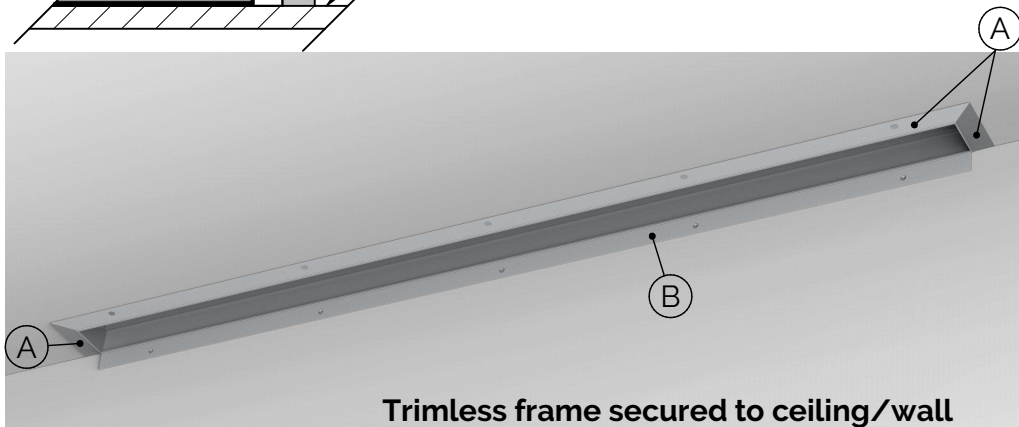
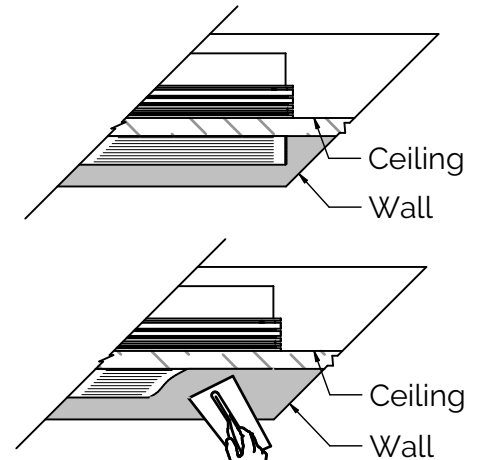
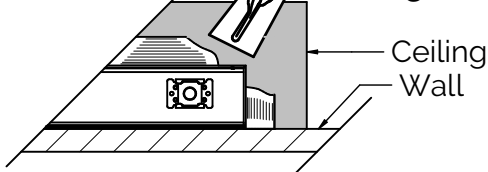
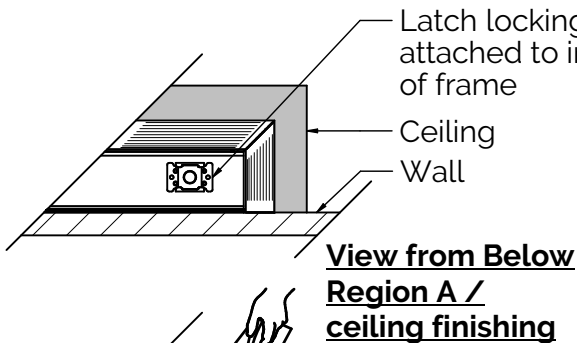

LeeSti Legato Ceiling Trimless

Installation Instructions

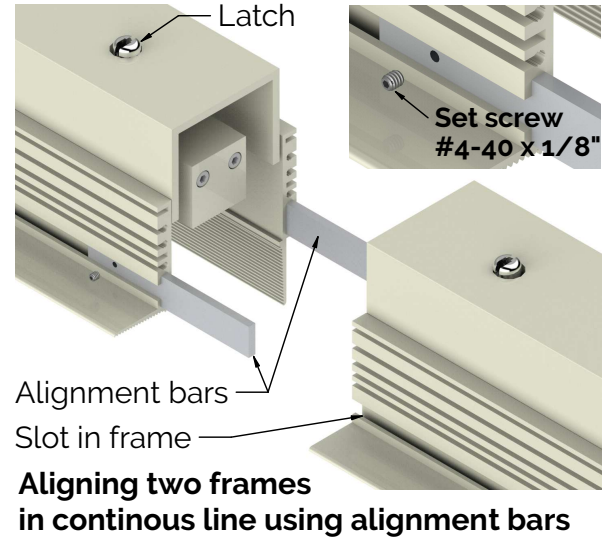
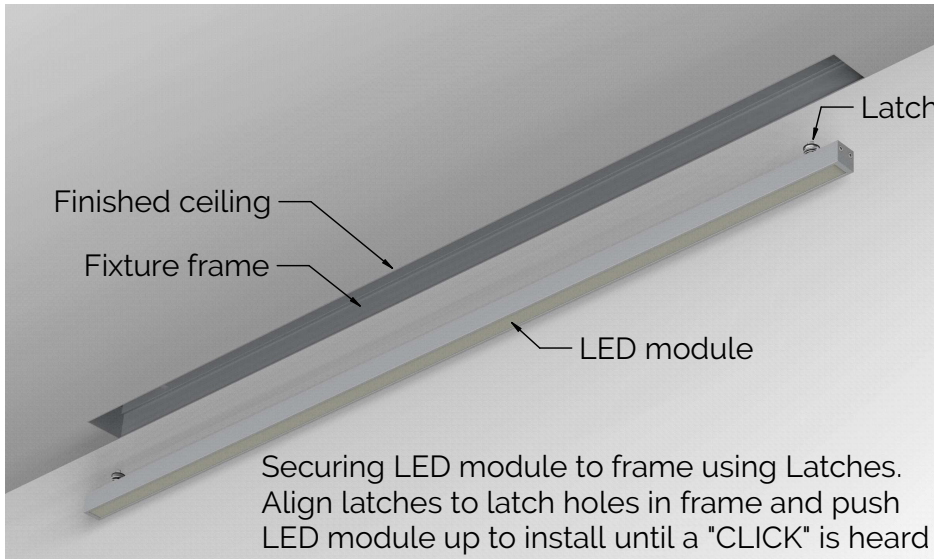

7. Connect LED module to Remote drivers (whip). Driver must be installed in a dry, accessible, and well ventilated remote location.

8. Make sure LED module is attached to fixture frame by a safety cable (aircraft cable) to prevent injury. Attach safety cable to a screw on Latch Post on LED module.

9. Insert LED module into frame completely by aligning Latches to latch hole and gently pushing upwards until a "CLICK" is heard from spring Latches. LED module must be secured in fixture frame at this point. Make sure LED power wire is not pinched as LED module is installed.

10. Connect AC Power Lead from LED Drivers to disconnected Mains power. Apply Mains power to fixture.

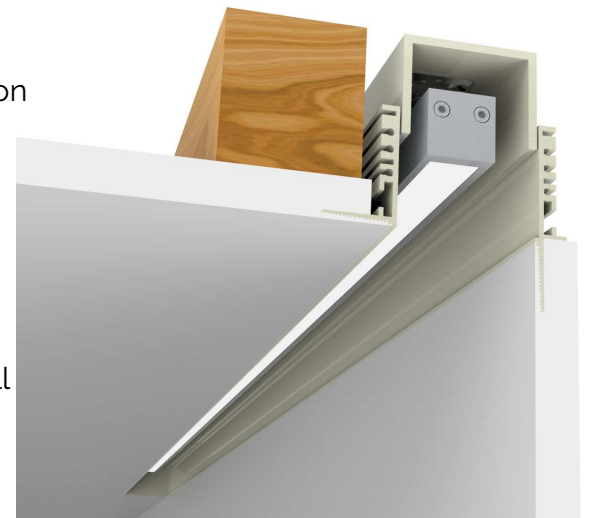
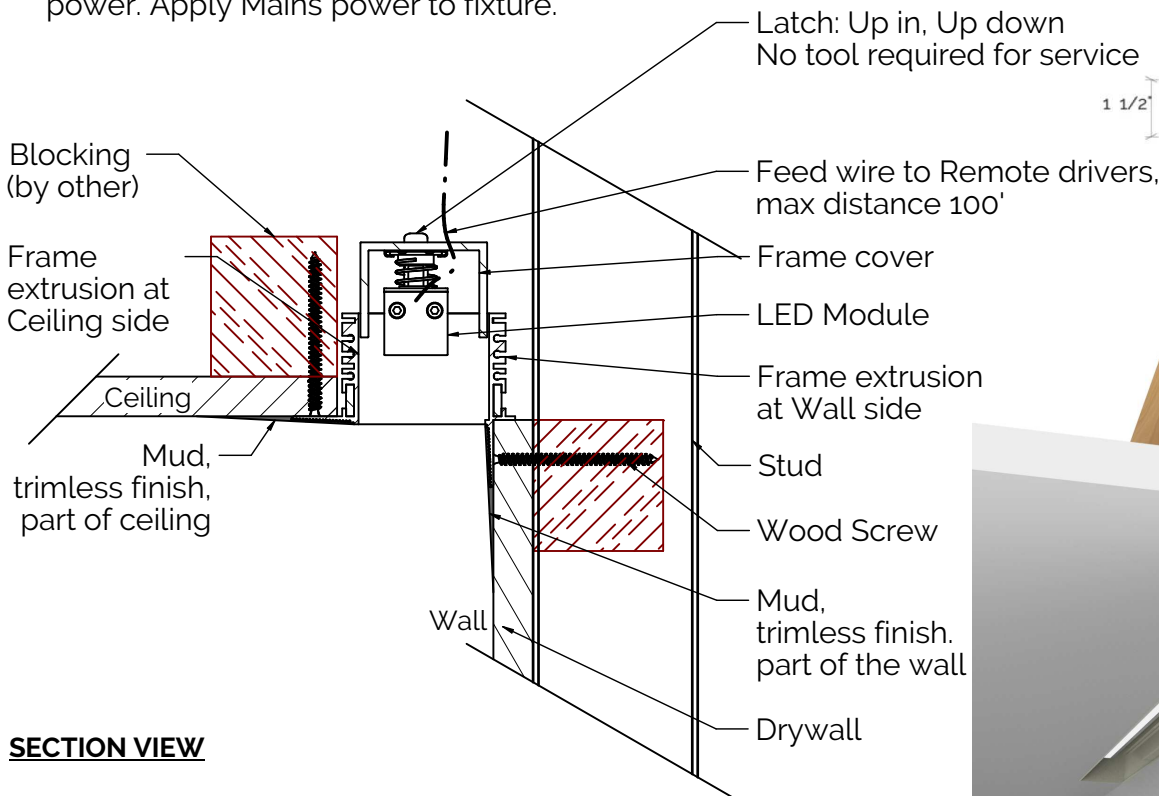
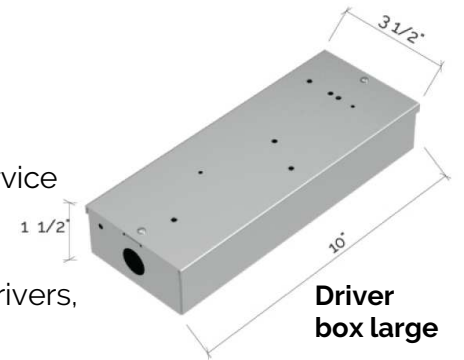
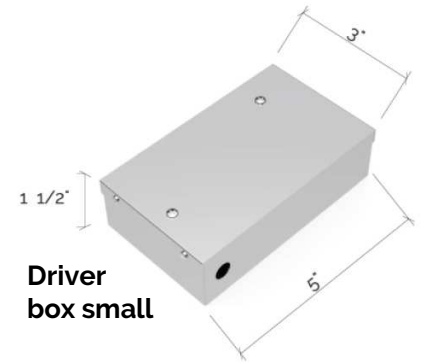

SECTION VIEW